

INSTALLATION INSTRUCTIONS

For Ops-Core® ARC-style, M-LOK® and Team Wendy® EXFIL® Rail Systems

MARK™

MODULAR
ATTACH
RAIL KIT

FOR OPS-CORE® AMP®
COMMUNICATION HEADSETS



 **UNITY™**

CONTENTS

PRODUCT OVERVIEW

MARK™ provides seamless integration of the Ops-Core® AMP® Communication Headset with most popular helmet rails, including Ops-Core® ARC-style, M-LOK® and Team Wendy® EXFIL® rail systems.

Two (2) MARK™ Wire Forms
for the Ops-Core® AMP®
Communication Headset

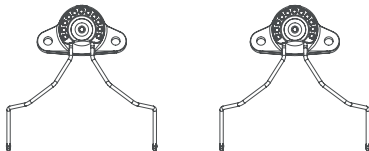

Two (2) ARC Rail Adapter Plates
(Note: Not used on Team Wendy®
EXFIL® rails.)

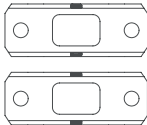

Two (2) Ops-Core® Cradle Clamps
(Optional Purchase)

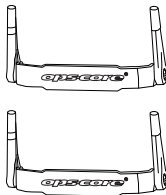

Four (4) 10-32 x 7/16 Screws



Four (4) 10-32 x 5/16 Screws



Four (4) Capture Nuts



NOTE

MARK™ M-LOK® Adapter Kit
sold separately.

ATTACHING AMP® TO MARK™



NOTE

If your AMP® has a headband, it must be fully disassembled from the headband before proceeding with installation. Unfasten the three loop fastener cable retention tabs on the headband to free the ear-to-ear cable.

If you purchased your MARK™ with the Ops-Core® Cradle Clamps, jump to step 2.

1

Holding one side of your existing wire form, twist one of the stems 90°. Pull the stem off the wire. Repeat on second wire until the clamp is fully detached on both sides. Then, repeat on second ear cup.

2

Holding one side of your MARK™ wire form, twist one wire 90° from the final origin of the clamp and insert it fully into the stem. Repeat on second wire until the clamp is fully attached on both sides. Then, repeat on second ear cup.

3

If not already attached to each ear cup, ensure the logo on the Ops-Core® Cradle Clamp is properly oriented right-side up, and the arrow on the inside of the clamp is pointing up. Insert one side of the Cradle Clamp into the hole on the side of the ear cup and push down to snap it in place. Repeat on opposite side until you hear a click and find it fully attached. Repeat on second ear cup.

ATTACHING MARK™ TO ARC-STYLE RAILS

NOTE

The ARC Adapter Plates are designed to work with genuine Ops-Core® ARC rails. They are also compatible with similar ARC-style rails, but may require slight fitting. If the ARC Adapter Plate is too tight in a non-Ops-Core® rail, carefully remove material with a fine grit sandpaper until optimal fit is achieved.

1 Install two Capture Nuts into the rear side of the ARC Adapter Plate as shown.

2 Slide the ARC Adapter Plate assembly into the center channel on the ARC rail.

3 Using the included 10-32 x 5/16 Screws (shorter screws), secure MARK™ assembly to the backer. Lightly snug both screws before applying torque to either. **Do not exceed 10 in-lbs (1.13 Nm).**

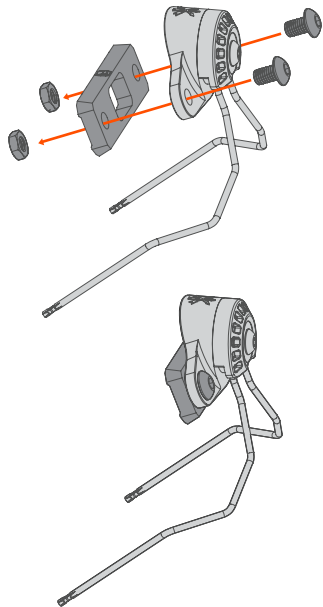

ATTACHING MARK™ TO TEAM WENDY® EXFIL® RAILS

1

If not already uninstalled, remove the two OEM screws holding the W Spacer Plate in place from both Team Wendy® EXFIL® 2.0 or 3.0 rails. Leave the W Spacer Plate in place.

2

Using the included 10-32 x 7/16 Screws (longer screws), secure MARK™ assembly to the rail. Lightly snug both screws before applying torque to either.

Do not exceed 10 in-lbs (1.13 Nm).

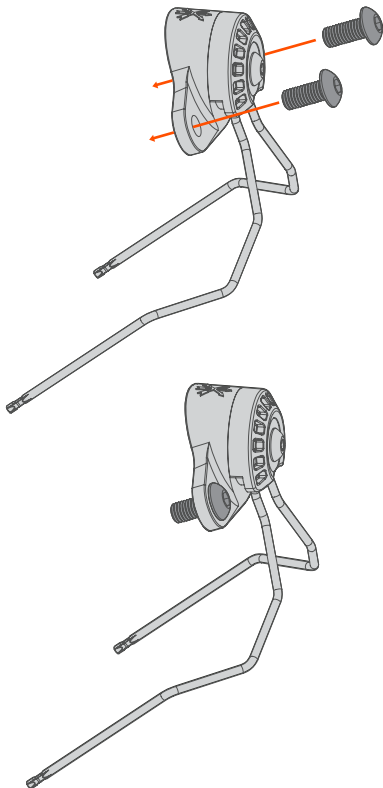

ATTACHING MARK™ TO M-LOK® RAILS

NOTE

MARK™ M-LOK® Adapter Kit sold separately.

1

Using the 10-32 x 3/8 Screws and M-LOK® Nuts included separately with the MARK™ M-LOK® Adapter Kit, insert the Screws through the MARK™ body and into the M-LOK® Nuts as shown.

2

Secure the MARK™ assembly to the M-LOK® helmet rail using normal M-LOK® mounting procedures. Lightly snug both screws before applying torque to either. **Do not exceed 10 in-lbs (1.13 Nm).**

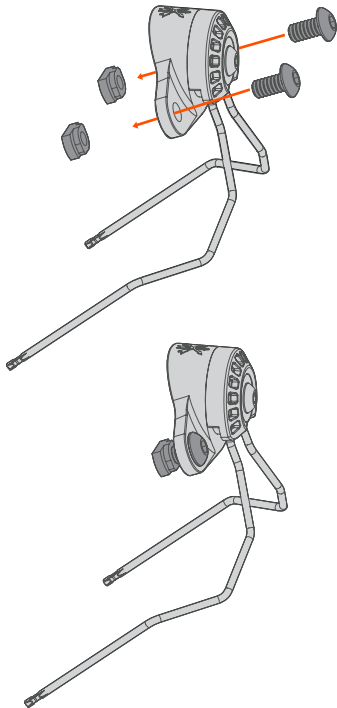

INFO@UNITYTACTICAL.COM

©2024 UNITY Tactical. All Rights Reserved.
Specifications subject to change without notice. PAT. UTIP.CO

